

NEW FLOATING PUMP

Model: SHTS-FP1000

Performance 1000 LPM
& 4,3 bar officially certified

New floating pump SIF - FP-1000 with a superb new design and the highest performance in its category.

Perfect solution for pumping water from natural sources and filling up water tenders. Efficient helper for firefighters and wherever a rapid intervention is required (municipal services, forests, buildings or construction companies).

USE FOR:

- Filling up water tenders • Drainage of flooded areas • Extinguishing fires

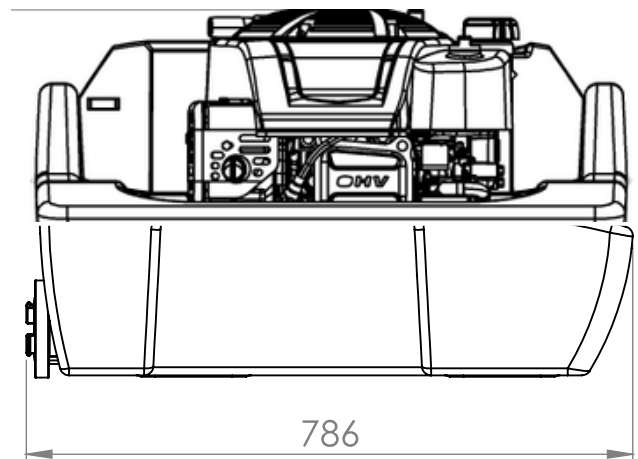
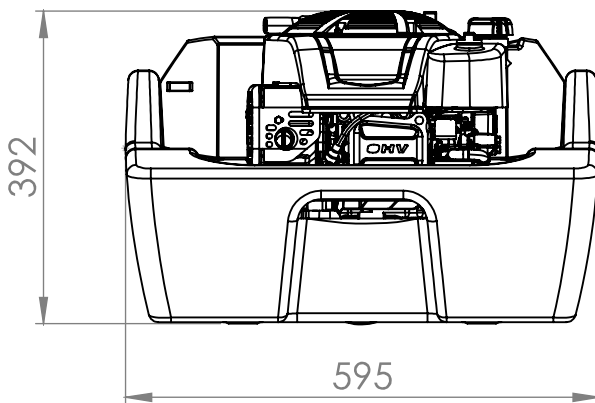

PARAMETERS

Nominal max. output	1000 LPM	Starting system	Recoil Start
Nominal max. pressure	4,3 bar	Tank capacity	1.5 L
Pumping head	Up to 43 m of water column	Pump Body	Aluminium
Outlet diameter	63 mm	Engine	6.9hp
Min. suction depth	15 mm	Weight	28 kg
Engine	B & S / Honda / Ha-ko	Dimensions	750 x 520 x 400 mm

Regd. Office: 16, Manav Vihar Society, Sector-15, Rohini, New Delhi-110089

Factory- Khasra 93/17, Road No-01, Mundka Udyog Nagar, South Side, New Delhi-110041

E-mail: sunhitechsol@yahoo.com

Website: www.sunhitechsolutions.com

